

HIGH SPEED FET INPUT BUFFERS
WITH OVERVOLTAGE PROTECTION

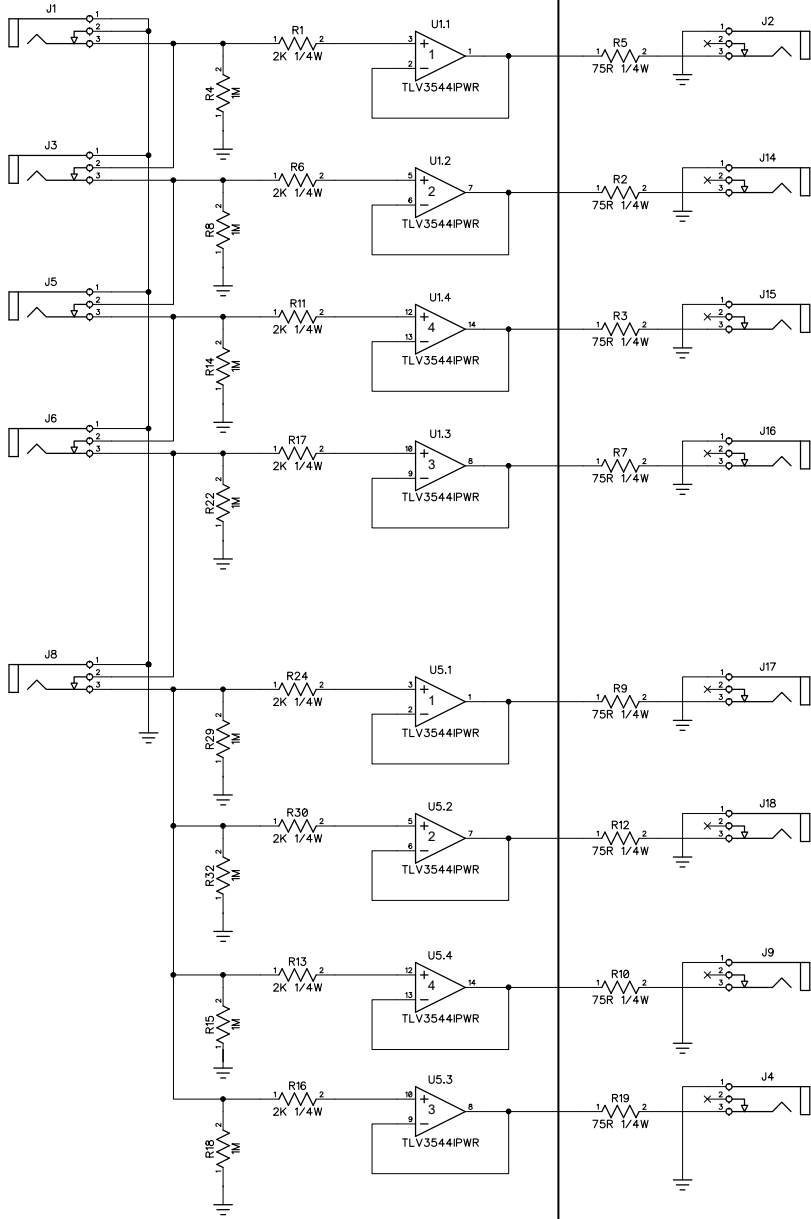

LZX INDUSTRIES

PAB

ACTIVE BUFFERS

4HP EURORACK MODULE

DESIGN BY LARS LARSEN

REVB

FEB 2025

PAGE 1/2

MAIN CIRCUIT

POWER RAIL CONNECTIONS & BYPASS CAPACITORS

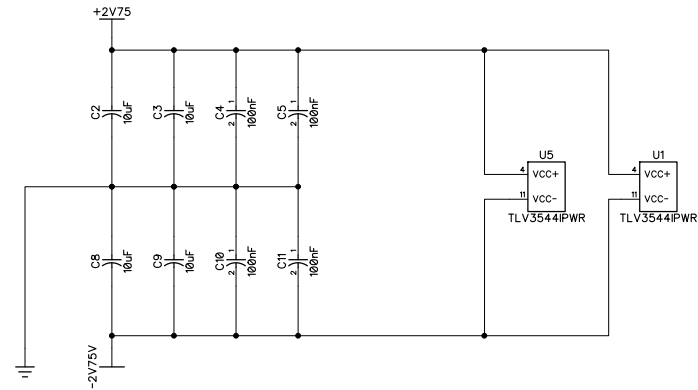

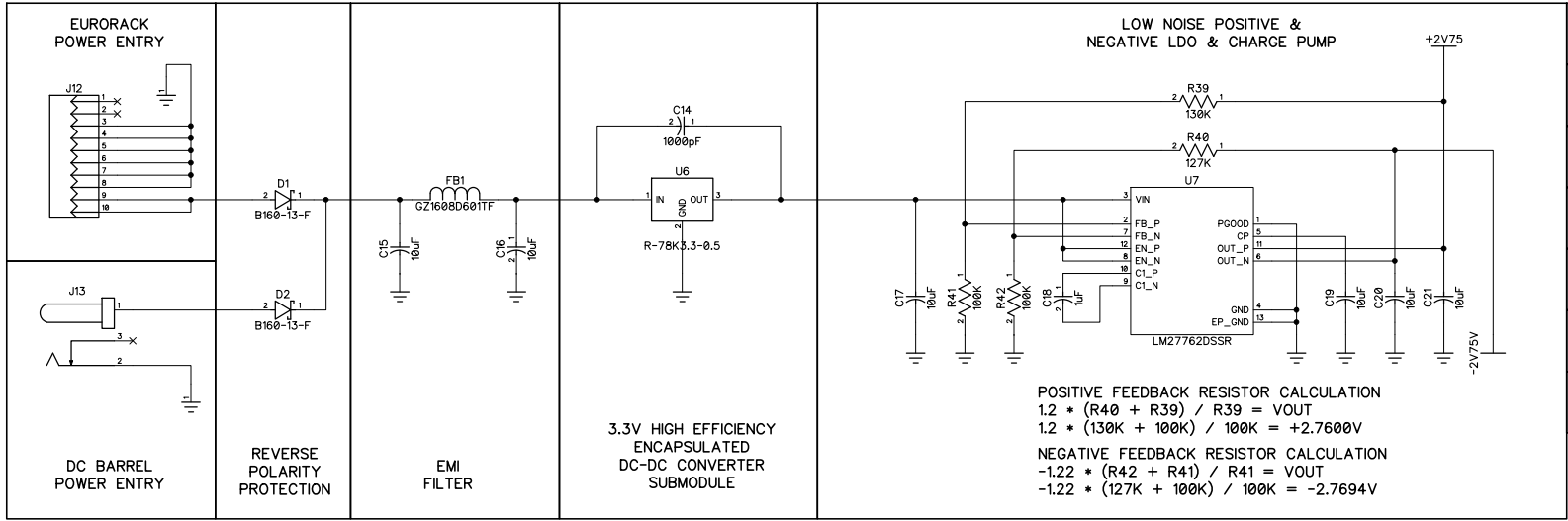

LZX INDUSTRIES	
PAB	
ACTIVE BUFFERS	
6HP EURORACK MODULE	
DESIGN BY LARS LARSEN	
REVB	FEB 2025
PAGE 2/2	POWER SUPPLY